

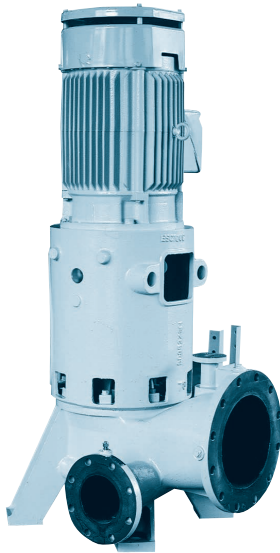

CENTRIFUGAL PUMP

CVC



Application

Condensate Pump

Feature

Vertical Single-stage Single-suction

Structure & Material

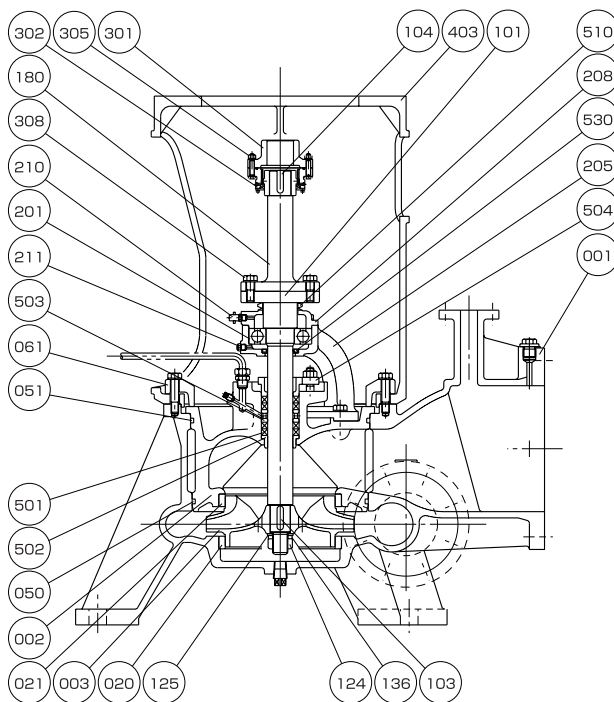

Part No.	Name	Req. No.	Fresh Water		Part No.	Name	Req. No.	Fresh Water	
			Material	JIS				Material	JIS
001	CASING	1	CAST IRON	FC200	205	BEARING HOUSING	1	CAST IRON	FC200
002	CASING COVER	1	CAST IRON	FC200	208	BEARING COVER	1	CAST IRON	FC200
003	IMPELLER	1	PHOSPHOR BRONZE	CAC502A	210	GREASE NIPPLE	1	BRASS	C3602
020	CASING RING	1	BRONZE	CAC402	211	GREASE FITTING	1	BRASS	C3602
021	CASING RING	1	BRONZE	CAC402	301	COUPLING	1	CARBON STEEL	S45C
050	O-RING	1	RUBBER	NBR	302	COUPLING	1	CARBON STEEL	S45C
051	O-RING	1	RUBBER	NBR	305	COUPLING BOLT & NUT	4	Cr-MO STEEL	SCM435
061	FIXING PLATE	8	MILD STEEL	SS400	308	BOLT	4	MILD STEEL	SS400
101	SHAFT	1	STAINLESS STEEL	SUS304	403	FRAME	1	CAST IRON	FC200
103	KEY	1	STAINLESS STEEL	SUS304	501	GLAND PACKING	4	CARBONIZED FIBER	-
104	KEY	1	CARBON STEEL	S45C	502	NECK BUSH	1	BRONZE	CAC402
124	IMPELLER NUT	1	STAINLESS STEEL	SUS304	503	LANTERN RING	1	BRONZE	CAC402
125	IMPELLER WASHER	1	STAINLESS STEEL	SUS304	504	GLAND	1	BRONZE	CAC402
136	SPRING WASHER	1	STAINLESS STEEL	SUS304	510	V-RING	1	RUBBER	NBR
180	COUPLING SPACER	1	CARBON STEEL	S45C	530	OIL SEAL	1	RUBBER	NBR
201	BALL BEARING	1	BEARING STEEL	SUJ2					

Performance

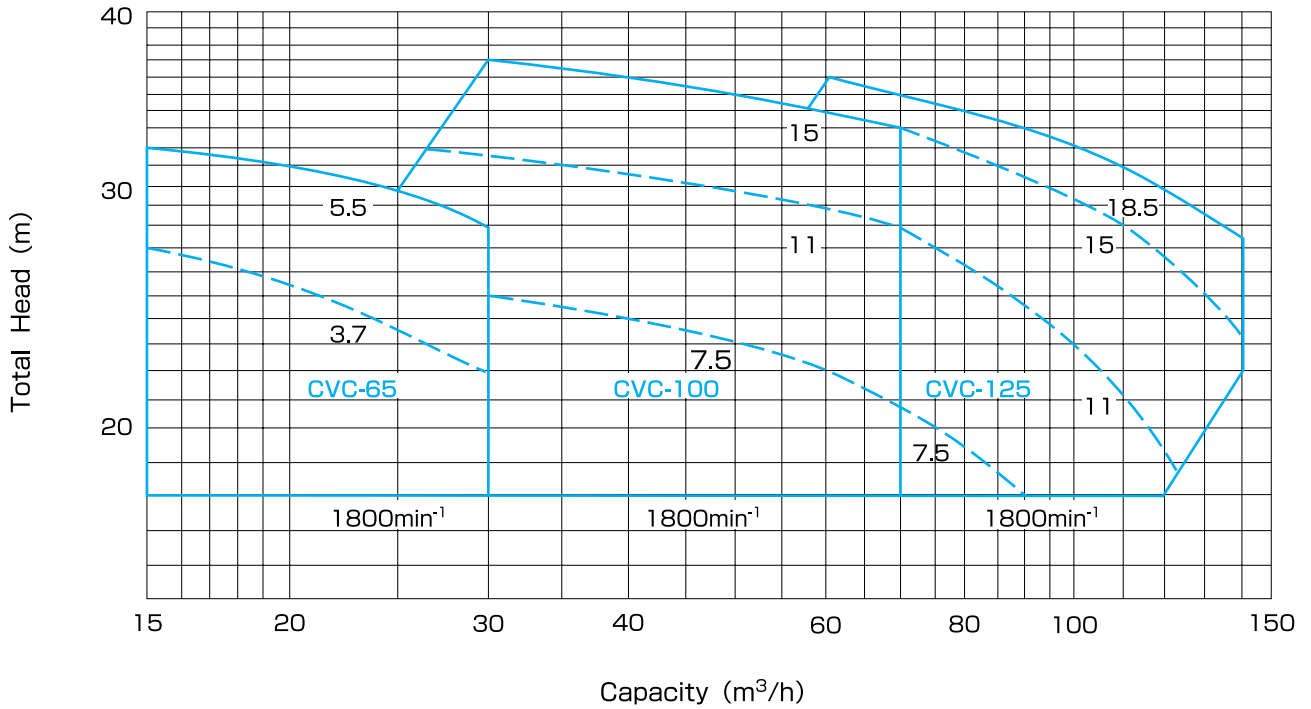

Dimension

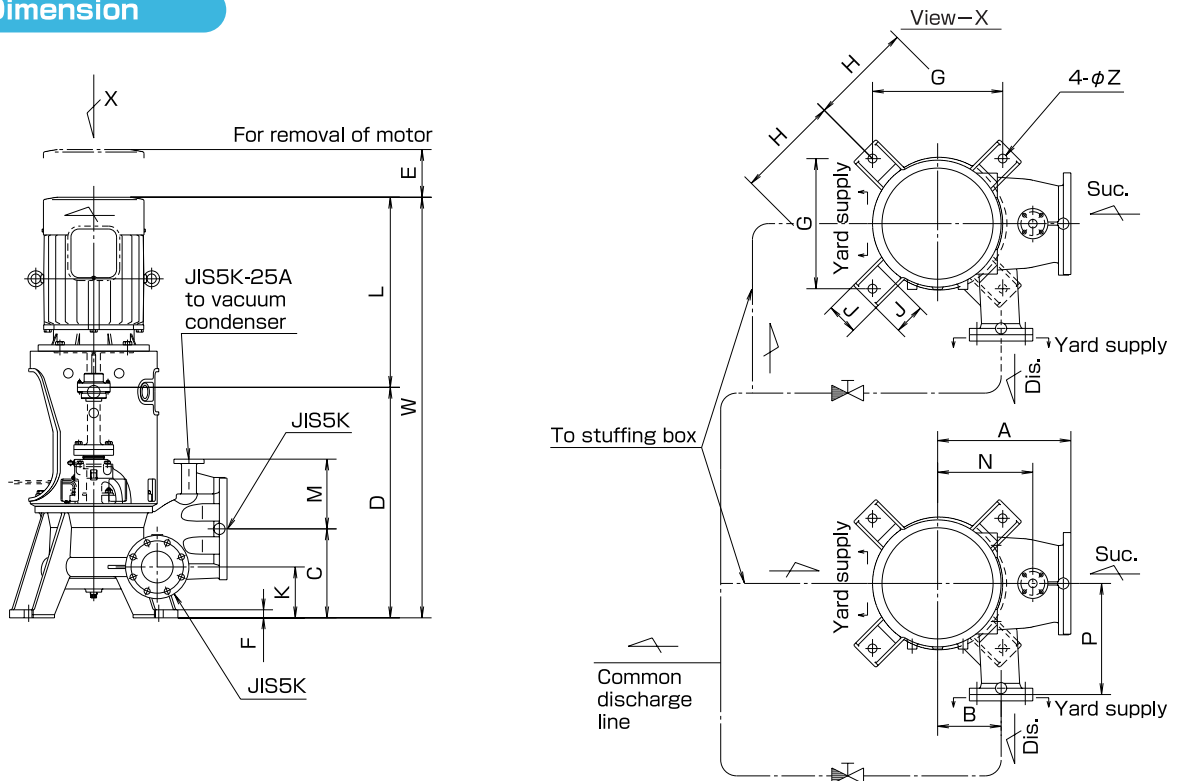

Model No.	Motor		Bore		Dimension (mm)															
	kW	min ⁻¹	Suc.	Dis.	A	B	C	D	E	F	G	H	J	K	L	M	N	P	W	Z
CVC-65	3.7	1800	125	65	380	160	160	604	150	25	290	240	100	85	428	140	270	280	1032	28
	5.5								455						1059					
CVC-100	7.5	1800	200	100	420	200	280	850	150	25	410	325	100	160	493	220	300	350	1343	28
	11								595						1445					
	15								635						1485					
CVC-125	7.5	1800	250	125	420	200	280	850	150	25	410	325	100	160	493	220	300	350	1343	28
	11								595						1445					
	15								635						1485					
	18.5								685						1535					