

CENTRIFUGAL PUMP

C1T · C2T

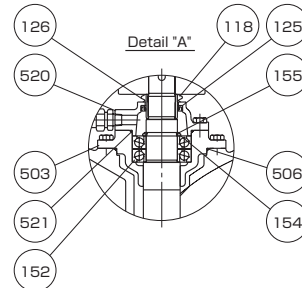
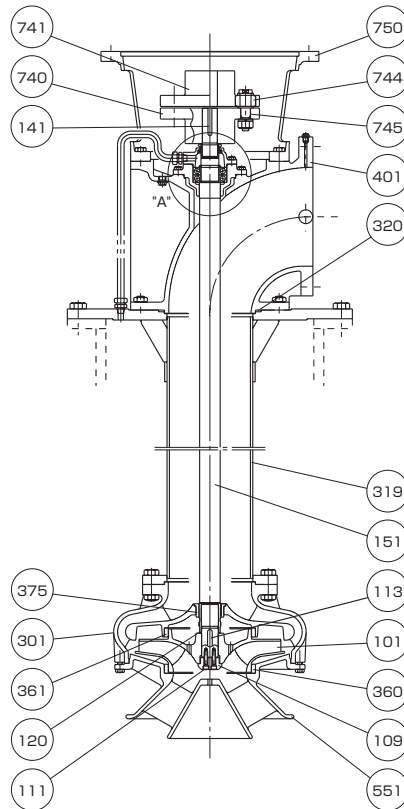

Application

Lubricating Oil Pump

Feature

Vertical Tank-mounted Type

Structure & Material

Part No.	Name	Req. No.	Lubricating Oil		Part No.	Name	Req. No.	Sea Water	
			Material	JIS				Material	JIS
101	IMPELLER	1	PHOSPHOR BRONZE	CAC502A	320	O-RING	1	RUBBER	NBR
109	HUB CAP	1	CARBON STEEL	S45C	360	CASING RING	1	BRONZE	CAC402
111	SCREW	2	Cr-Mo STEEL	SCM435	361	CASING RING	1	BRONZE	CAC402
113	KEY	1	CARBON STEEL	S45C	375	BEARING BUSH	1	BRONZE	CAC402
118	SLEEVE	1	STAINLESS STEEL	SUS420J2	401	DELIVERY BEND	1	CAST IRON	FC200
120	SLEEVE	1	STAINLESS STEEL	SUS420J2	503	BEARING HOUSING	1	CAST IRON	FC200
125	OIL SEAL	1	RUBBER	NBR	506	O-RING	1	RUBBER	NBR
126	V-RING	1	RUBBER	NBR	520	BEARING COVER	1	CAST IRON	FC200
141	KEY	1	CARBON STEEL	S45C	521	O-RING	1	RUBBER	NBR
151	SHAFT	1	CARBON STEEL	S45C	551	SUCTION COVER	1	CAST IRON	FC200
152	BALL BEARING	1SET	BEARING STEEL	SUJ2	740	COUPLING	1	CAST IRON	FC200
154	WASHER	1	MILD STEEL	SS400	741	COUPLING	1	CAST IRON	FC200
155	SNAP RING	1	CARBON TOOL STEEL	SK5	744	COUPLING RING	8	RUBBER	NBR
301	GUIDE VANE CASING	1	CAST IRON	FC200	745	COUPLING BOLT & NUT	8	MILD STEEL	SS400
319	COLUMN PIPE	1	CARBON STEEL PIPE	STPG370	750	MOTOR FRAME	1	CAST IRON	FC200

Performance

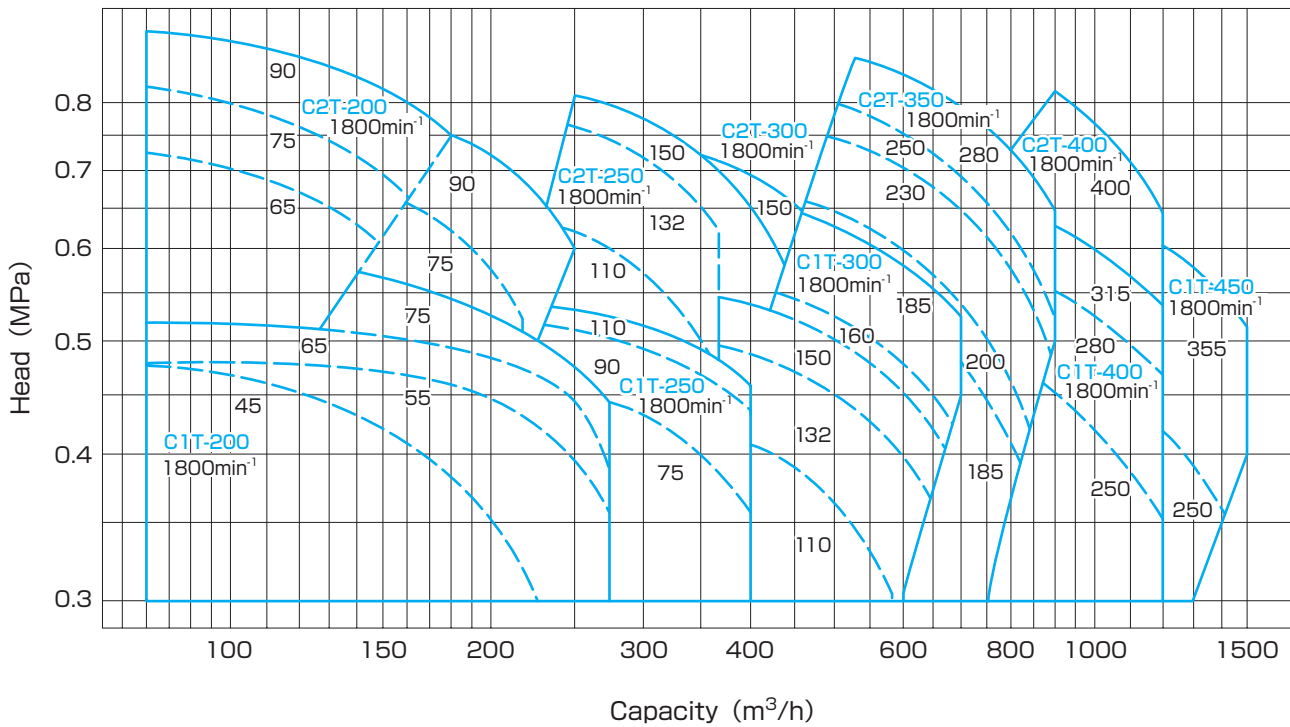

Dimension

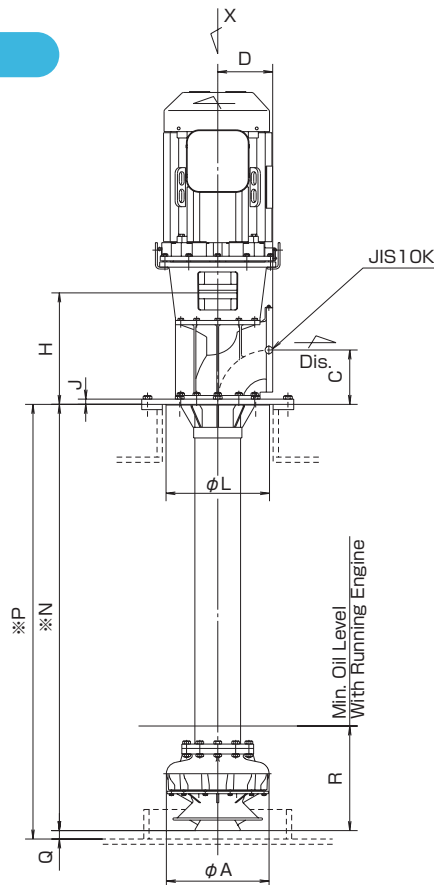

Based on lubrication oil at 75 mm²/s,
specific gravity 0.9

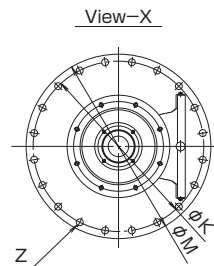

※ (1) N & P dimensions are adjusted to Tank depth.
 (2) Long shaft is equipped with intermediate bearing.

Model No.	Bore Dis.	Dimension (mm)												
		A	C	D	H	J	K	L	M	N	P	Q	R	Z
C1T-200	200	475	233	260	498	25	605	480	655	-	-	40	350	20-φ25
C1T-250	250	485	258	260	533	25	665	495	720	-	-	40	350	20-φ27
C1T-300	300	540	282	290	587	29	665	550	720	-	-	40	350	20-φ27
C1T-400	400	635	400	400	855	32	770	645	825	-	-	40	550	24-φ27
C1T-450	450	680	450	425	930	32	820	685	875	-	-	40	500	24-φ27
C2T-200	200	475	233	260	498	25	605	480	655	-	-	40	350	20-φ25
C2T-250	250	485	258	260	533	25	665	495	720	-	-	40	350	20-φ27
C2T-300	300	540	282	290	587	29	665	550	720	-	-	40	350	20-φ27
C2T-350	350	570	315	355	743	32	715	580	770	-	-	40	560	20-φ27
C2T-400	400	635	400	400	855	32	770	645	825	-	-	40	655	24-φ27