

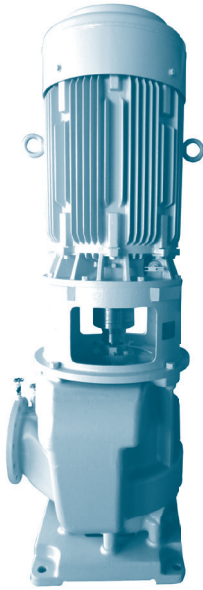

CENTRIFUGAL PUMP

EMS-260MC



Application

Fire & G.S. Pump
Bilge & Ballast Pump

Feature

Vertical Two-stage Single-suction
Closed Coupling Type

Structure & Material

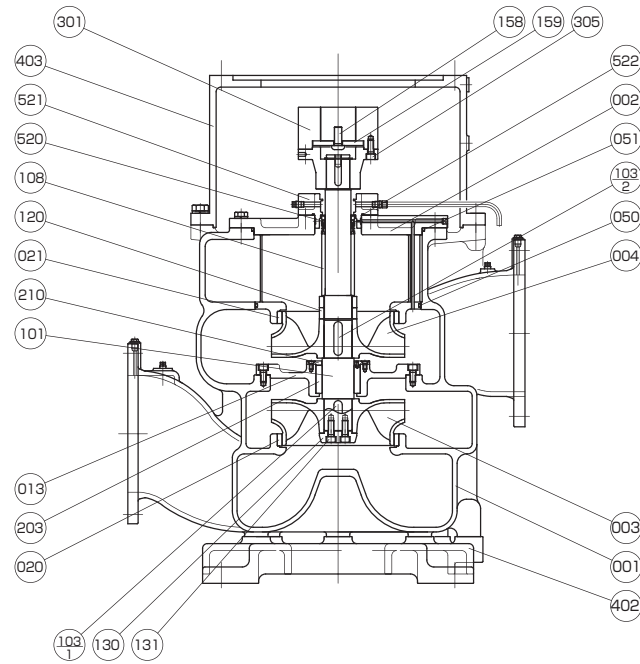

Part No.	Name	Req. No.	Sea Water		Fresh Water		Part No.	Name	Req. No.	Sea Water		Fresh Water	
			Material	JIS	Material	JIS				Material	JIS		
001	CASING	1	BRONZE	CAC402	DUCTILE CAST IRON	FCD400	130	HUB CAP	1	STAINLESS STEEL	SUS304	STAINLESS STEEL	SUS304
002	CASING COVER	1	BRONZE	CAC402	DUCTILE CAST IRON	FCD400	131	SCREW	2	STAINLESS STEEL	SUS304	STAINLESS STEEL	SUS304
003	IMPELLER	1	PHOSPHORE BRONZE	CAC502A	PHOSPHORE BRONZE	CAC502A	158	SET SCREW	1	Cr-Mo STEEL	SCM435	Cr-Mo STEEL	SCM435
004	IMPELLER	1	PHOSPHORE BRONZE	CAC502A	PHOSPHORE BRONZE	CAC502A	159	STOPPER RING	1	MILD STEEL	SS400	MILD STEEL	SS400
013	STAGE	1	BRONZE	CAC402	DUCTILE CAST IRON	FCD400	203	CARBON METAL	1	CARBON	-	CARBON	-
020	CASING RING	1	BRONZE	CAC402	BRONZE	CAC402	210	METAL COVER	1	BRONZE	CAC402	BRONZE	CAC402
021	CASING RING	1	BRONZE	CAC402	BRONZE	CAC402	301	COUPLING	1	CARBON STEEL	S45C	CARBON STEEL	S45C
050	O-RING	1	RUBBER	NBR	RUBBER	NBR	305	COUPLING BOLT	8	Cr-Mo STEEL	SCM435	Cr-Mo STEEL	SCM435
050	O-RING	1	RUBBER	NBR	RUBBER	NBR	402	PUMP BED	1	CAST IRON	FC200	CAST IRON	FC200
101	SHAFT	1	STAINLESS STEEL	SUS304	STAINLESS STEEL	SUS304	403	FRAME	1	CAST IRON	FC200	CAST IRON	FC200
103/1	KEY	1	STAINLESS STEEL	SUS304	STAINLESS STEEL	SUS304	520	MECHANICAL SEAL	1	SiC & CARBON	-	SiC & CARBON	-
103/2	KEY	1	STAINLESS STEEL	SUS304	STAINLESS STEEL	SUS304	521	MECH. SEAL COVER	1	BRONZE	CAC402	BRONZE	CAC402
108	SPACER	1	STAINLESS STEEL	SUS304	STAINLESS STEEL	SUS304	522	O-RING	1	RUBBER	NBR	RUBBER	NBR
120	IMPELLER NUT	2	STAINLESS STEEL	SUS304	STAINLESS STEEL	SUS304							

Performance

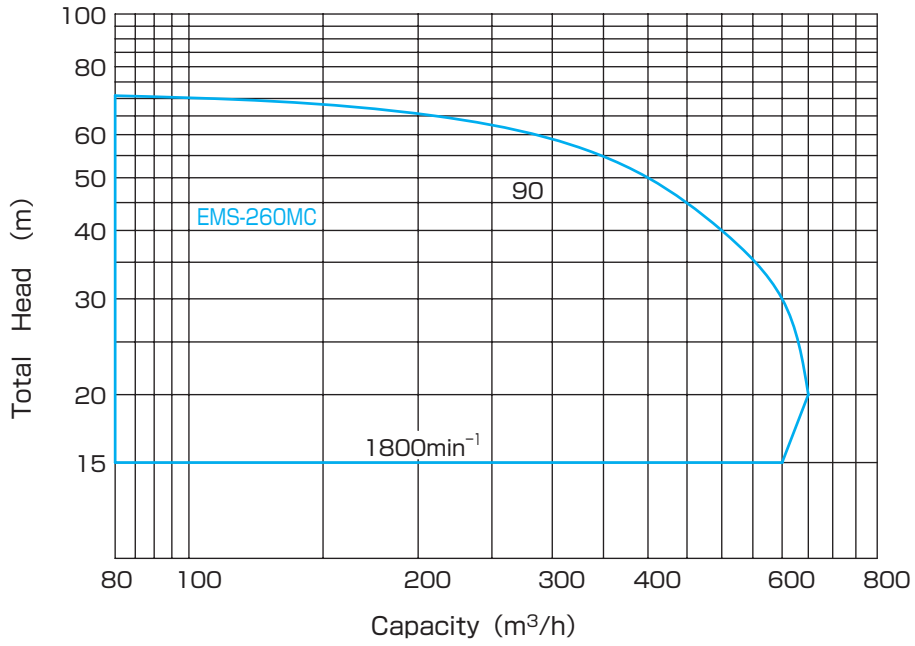

Dimension

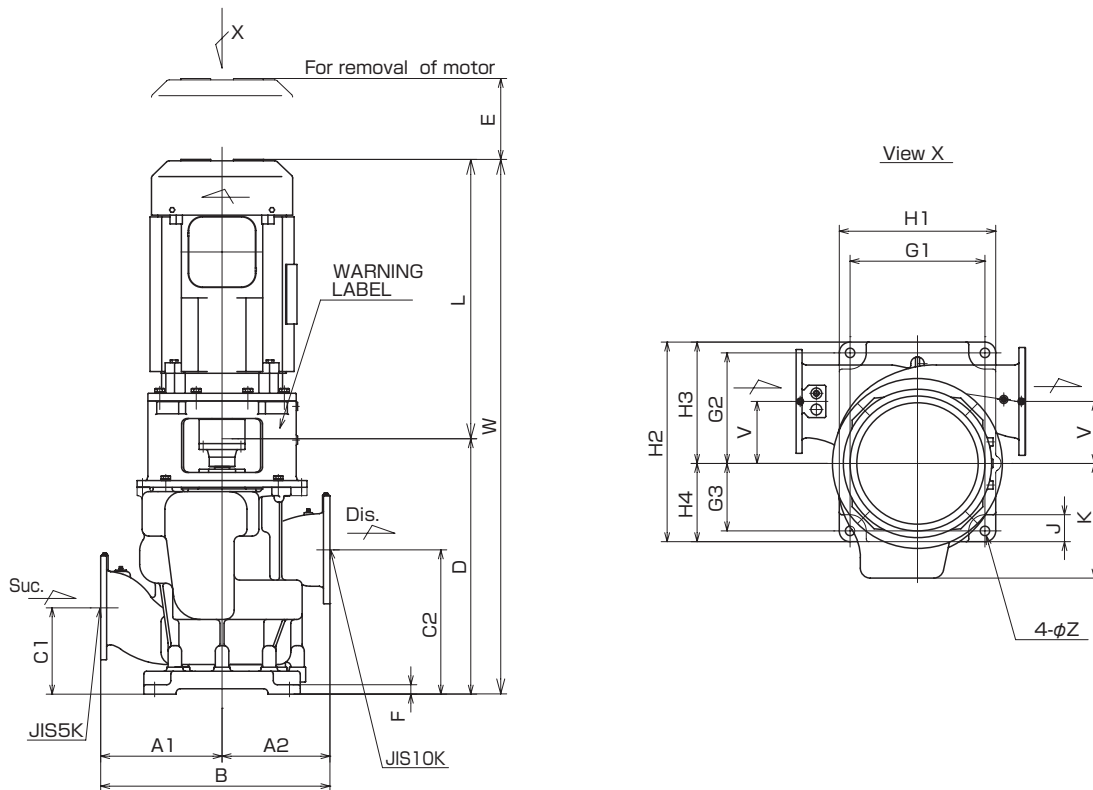

Model No.	Motor		Bore		Dimension(mm)										
	kW	min ⁻¹	Suc.	Dis.	A1	A2	8	C1	C2	D	E	F	G1	G2	G3
EMS-260MC	90	1800	250	250	450	400	850	320	535	947	250	35	500	410	250
					H1	H2	H3	H4	J	K	V	L	W	Z	
					580	740	450	290	100	440	230	1050	1725	35	