



# CENTRIFUGAL PUMP

## ESD



### Application

- Cooling Sea Water Pump
- Ballast Pump
- Condenser Cooling Pump

### Feature

- Vertical Single-stage Double-suction
- Spacer Coupling Type

### Structure & Material

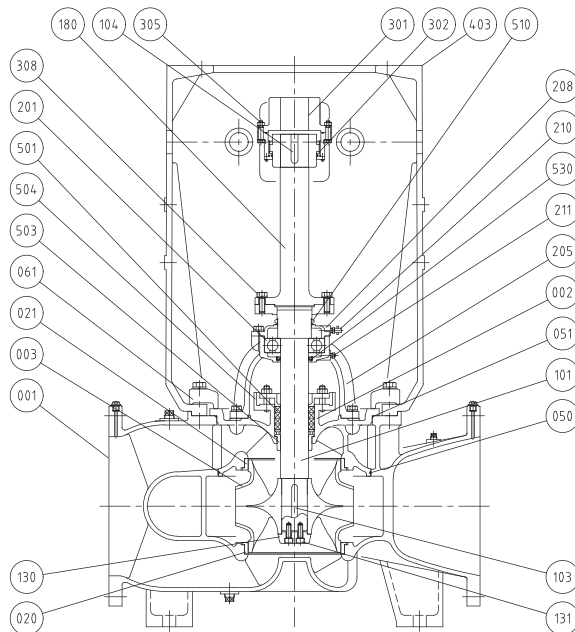

Part No.	Name	Req. No.	Sea Water		Fresh Water	
			Material	JIS	Material	JIS
001	CASING	1	BRONZE	CAC402	CAST IRON	FC200
002	CASING COVER	1	BRONZE	CAC402	CAST IRON	FC200
003	IMPELLER	1	PHOSPHOR BRONZE	CAC502A	PHOSPHOR BRONZE	CAC502A
020	CASING RING	1	BRONZE	CAC402	BRONZE	CAC402
021	CASING RING	1	BRONZE	CAC402	BRONZE	CAC402
050	O-RING	1	RUBBER	NBR	RUBBER	NBR
051	O-RING	1	RUBBER	NBR	RUBBER	NBR
061	FIXING PLATE	8	DUCTILE CAST IRON	FCD400	DUCTILE CAST IRON	FCD400
101	SHAFT	1	STAINLESS STEEL	SUS304	STAINLESS STEEL	SUS304
103	KEY	1	STAINLESS STEEL	SUS304	STAINLESS STEEL	SUS304
104	KEY	1	CARBON STEEL	S45C	CARBON STEEL	S45C
130	HUB CUP	1	STAINLESS STEEL	SUS304	STAINLESS STEEL	SUS304
131	SCREW	2	STAINLESS STEEL	SUS304	STAINLESS STEEL	SUS304
180	COUPLING SPACER	1	CARBON STEEL	S45C	CARBON STEEL	S45C
201	BALL BEARING	1	BEARING STEEL	SUJ2	BEARING STEEL	SUJ2

Part No.	Name	Req. No.	Sea Water		Fresh Water	
			Material	JIS	Material	JIS
205	BEARING HOUSING	1	CAST IRON	FC200	CAST IRON	FC200
208	BEARING COVER	1	CAST IRON	FC200	CAST IRON	FC200
210	GREASE NIPPLE	1	BRASS	C3602	BRASS	C3602
211	GREASE FITTING	1	BRASS	C3602	BRASS	C3602
301	COUPLING	1	CARBON STEEL	S45C	CARBON STEEL	S45C
302	COUPLING	1	CARBON STEEL	S45C	CARBON STEEL	S45C
305	COUPLING BOLT	8	Cr-Mo STEEL	SCM435	Cr-Mo STEEL	S45C
308	BOLT	8	MILD STEEL	SS400	MILD STEEL	SS400
403	FRAME	1	CAST IRON	FC200	CAST IRON	FC200
501	GLAND PACKING	4	CARBONIZED FIBER	-	CARBONIZED FIBER	-
503	LANTERN RING	1	BRONZE	CAC402	BRONZE	CAC402
504	GLAND	1	BRONZE	CAC402	BRONZE	CAC402
510	V-RING	1	RUBBER	NBR	RUBBER	NBR
530	OIL SEAL	1	RUBBER	NBR	RUBBER	NBR

## Performance

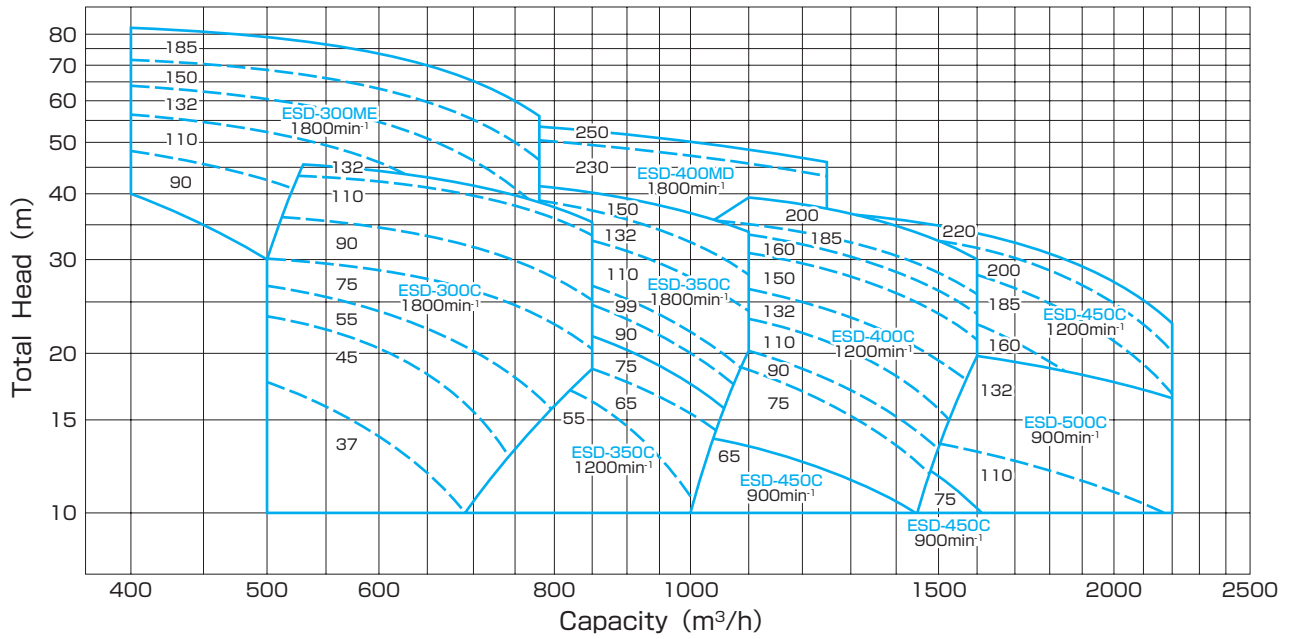

## Dimension

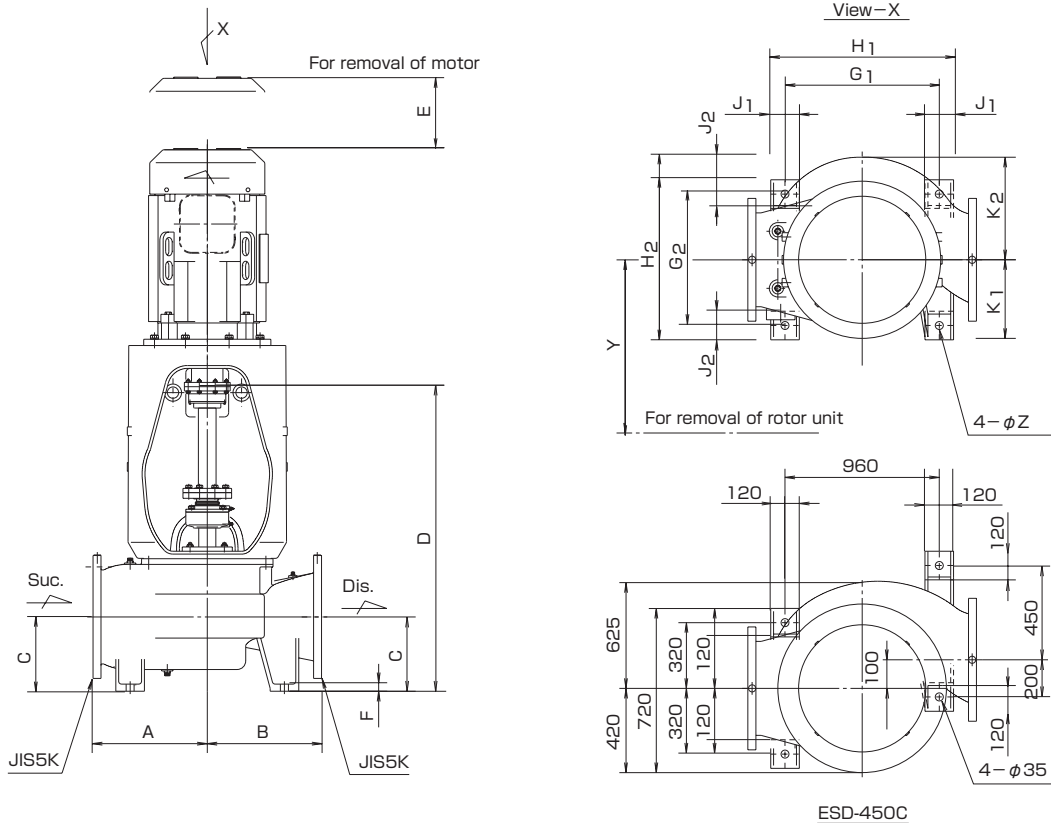

Model No.	Bore		Dimension (mm)																	
	Suc.	Dis.	A	B	C	D	E	F	G1	G2	H1	H2	J1	J2	K1	K2	Y	Z		
ESD-300C	300	300	400	400	260	1070	250	25	540	460	640	540	100	100	275	365	800	28		
ESD-300ME	300	250	450	450	260	1140	250	25	540	540	640	620	100	100	335	376	800	28		
ESD-350C	350	350	500	520	290	1325	250	30	600	600	720	680	120	120	330	380	800	35		
ESD-400C	400	400	550	550	300	1290	250	30	640	640	760	720	120	120	400	490	1000	35		
ESD-400MD	400	400	550	550	300	1290	250	30	640	640	760	720	120	120	400	490	1000	35		
ESD-450C	450	450	650	650	400	1560	250	30	-	-	-	-	-	-	-	-	1000	-		
ESD-500C (FC)	500	500	760	760	420	1650	300	35	960	800	1120	920	160	120	530	505	1100	48		
ESD-500C (BC)			750	750																