

# CENTRIFUGAL PUMP

## HD

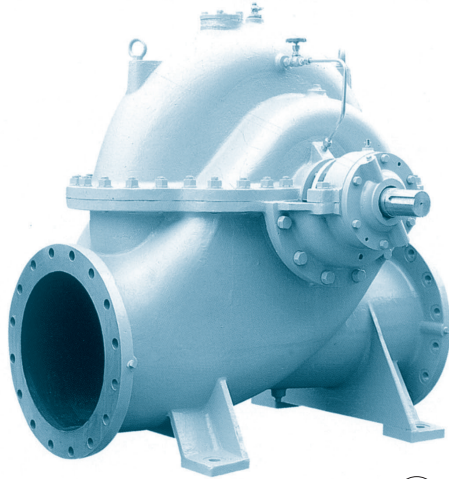

### Application

Ballast Pump

### Feature

Horizontal Single-stage Double-suction

### Structure & Material

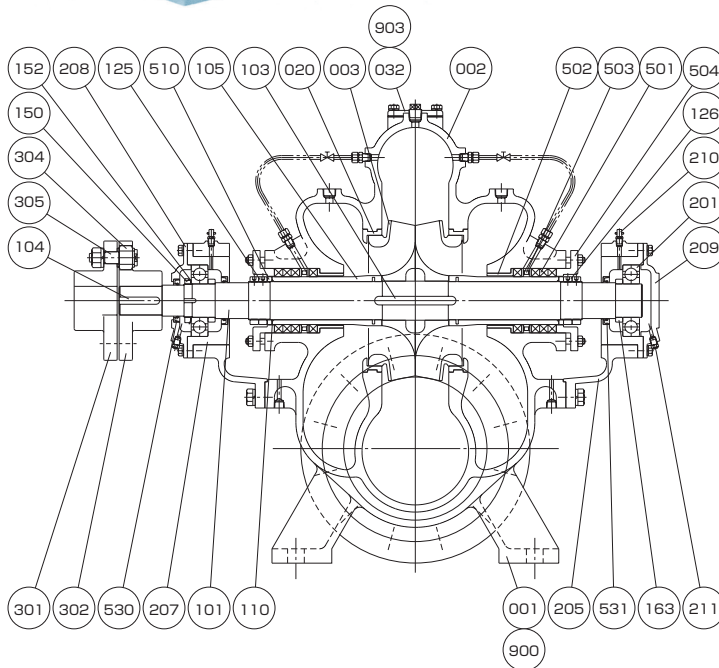

12-3

Part No.	Name	Req. No.	Sea Water		Fresh Water	
			Material	JIS	Material	JIS
001	CASING	1	BRONZE	CAC402	CAST IRON	FC200
002	CASING COVER	1	BRONZE	CAC402	CAST IRON	FC200
003	IMPELLER	1	PHOSPHOR BRONZE	CAC502A	PHOSPHOR BRONZE	CAC502A
020	CASING RING	2	BRONZE	CAC402	BRONZE	CAC402
032	BLIND COVER	1	CAST IRON	FC200	CAST IRON	FC200
101	SHAFT	1	STAINLESS STEEL	SUS304	STAINLESS STEEL	SUS304
103	KEY	1	STAINLESS STEEL	SUS304	STAINLESS STEEL	SUS304
104	KEY	1	CARBON STEEL	S45C	CARBON STEEL	S45C
105	SLEEVE	2	STAINLESS STEEL	SUS304	STAINLESS STEEL	SUS304
110	O-RING	2	RUBBER	NBR	RUBBER	NBR
125	SLEEVE NUT	2	STAINLESS STEEL	SUS304	STAINLESS STEEL	SUS304
126	SLEEVE NUT	2	STAINLESS STEEL	SUS304	STAINLESS STEEL	SUS304
150	BEARING NUT	1	MILD STEEL	SS400	MILD STEEL	SS400
152	BEARING WASHER	1	MILD STEEL	SS400	MILD STEEL	SS400
163	SPACER	2	MILD STEEL	SS400	MILD STEEL	SS400
201	BALL BEARING	2	BEARING STEEL	SUJ2	BEARING STEEL	SUJ2
205	BEARING HOUSING	2	CAST IRON	FC200	CAST IRON	FC200
207	BEARING INNER HOUSING	2	CAST IRON	FC200	CAST IRON	FC200

Part No.	Name	Req. No.	Sea Water		Fresh Water	
			Material	JIS	Material	JIS
208	BEARING COVER	1	CAST IRON	FC200	CAST IRON	FC200
209	BEARING COVER	1	CAST IRON	FC200	CAST IRON	FC200
210	GREASE NIPPLE	2	BRASS	C3602	BRASS	C3602
211	GREASE FITTING	2	BRASS	C3602	BRASS	C3602
301	COUPLING	1	CAST IRON	FC200	CAST IRON	FC200
302	COUPLING	1	CAST IRON	FC200	CAST IRON	FC200
304	COUPLING RING	8	RUBBER	NBR	RUBBER	NBR
305	COUPLING BOLT & NUT	8	MILD STEEL	SS400	MILD STEEL	SS400
501	GLAND PACKING	8	CARBONIZED FIBER	-	CARBONIZED FIBER	-
502	NECK BUSH	2	BRONZE	CAC402	BRONZE	CAC402
503	LANTERN RING	2	BRONZE	CAC402	BRONZE	CAC402
504	GLAND	2	BRONZE	CAC402	BRONZE	CAC402
510	PACKING RING	2	STAINLESS STEEL	SUS304	STAINLESS STEEL	SUS304
530	OIL SEAL	1	RUBBER	NBR	RUBBER	NBR
531	OIL SEAL	2	RUBBER	NBR	RUBBER	NBR
900	GASKET	1	PAPER	-	PAPER	-
903	GASKET	1	PAPER	-	PAPER	-

## Performance

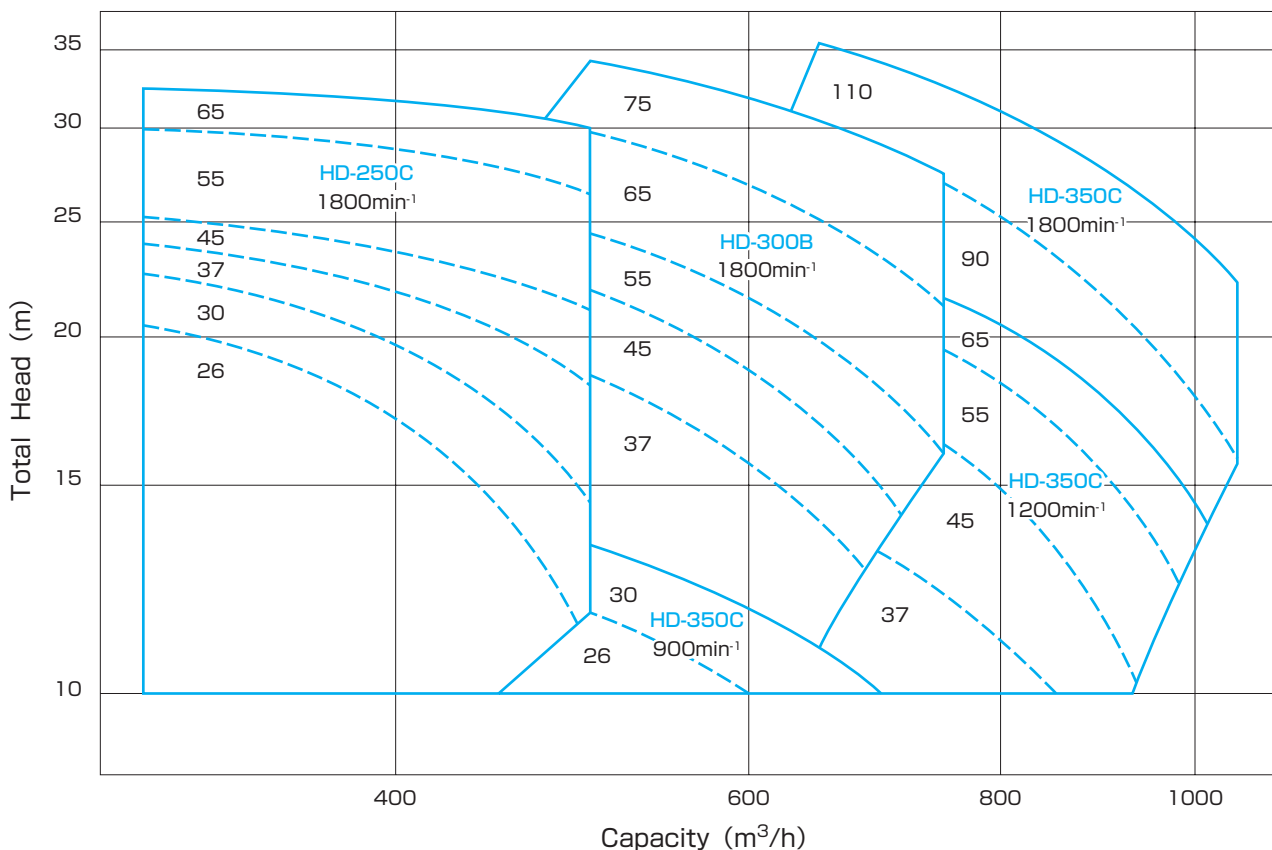

## Dimension

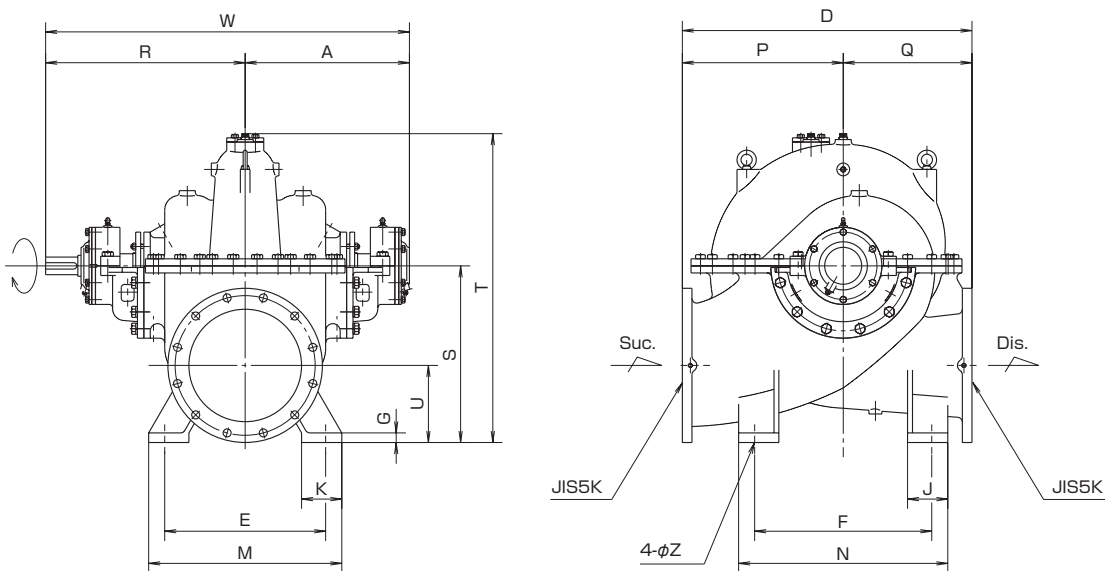

Model No.	Bore		Dimension (mm)																
	Suc.	Dis.	A	D	E	F	G	J	K	M	N	P	Q	R	S	T	U	W	Z
HD-250C	250	250	435	710	300	400	25	115	115	400	500	400	310	526	440	740	205	961	24
HD-300B	300	300	512	820	450	450	25	125	125	550	550	470	350	600	500	835	235	1112	24
HD-350C	350	300	510	900	500	550	30	125	125	600	650	500	400	620	550	928	240	1130	35