

HYDROPHORE TANK UNIT

UH

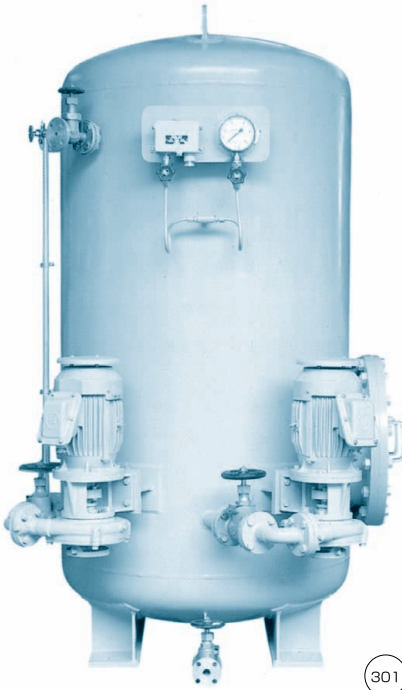

Application

Fresh Water
Sanitary Water
Drinking Water

Feature

F.W. & Sanitary

Structure & Material

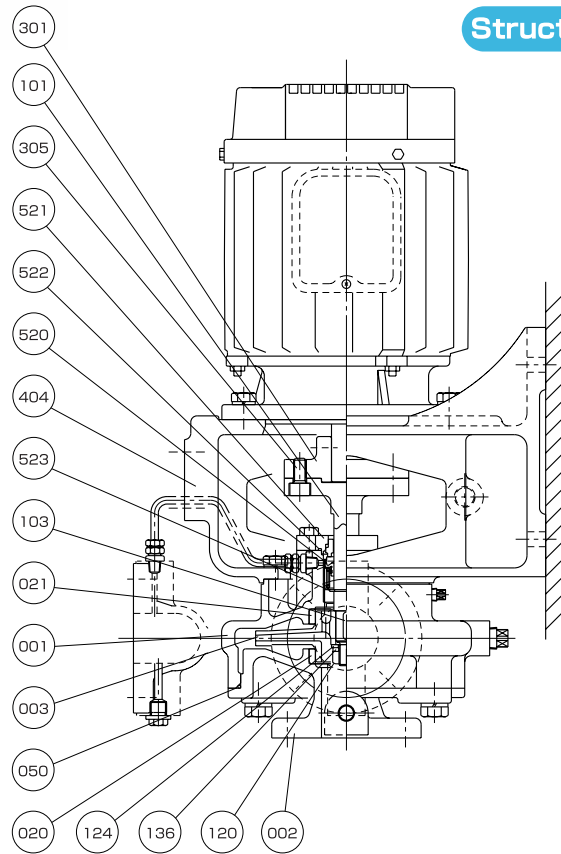

TMV-00MT TYPE

Part No.	Name	Req. No.	Sea Water		Fresh Water	
			Material	JIS	Material	JIS
001	CASING	1	BRONZE	CAC402	CAST IRON	FC200
002	CASING COVER	1	BRONZE	CAC402	CAST IRON	FC200
003	IMPELLER	1	PHOSPHOR BRONZE	CAC502A	PHOSPHOR BRONZE	CAC502A
020	CASING RING	1	BRONZE	CAC402	BRONZE	CAC402
021	CASING RING	1	BRONZE	CAC402	BRONZE	CAC402
050	O-RING	1	RUBBER	NBR	RUBBER	NBR
101	SHAFT	1	STAINLESS STEEL	SUS304	STAINLESS STEEL	SUS304
103	KEY	1	STAINLESS STEEL	SUS304	STAINLESS STEEL	SUS304
120	IMPELLER NUT	1	STAINLESS STEEL	SUS304	STAINLESS STEEL	SUS304

Part No.	Name	Req. No.	Sea Water		Fresh Water	
			Material	JIS	Material	JIS
124	IMPELLER WASHER	1	STAINLESS STEEL	SUS304	STAINLESS STEEL	SUS304
136	SPRING WASHER	1	STAINLESS STEEL	SUS304	STAINLESS STEEL	SUS304
301	COUPLING	1	MILD STEEL	SS400	MILD STEEL	SS400
305	COUPLING BOLT	4	Cr-Mo STEEL	SCM435	Cr-Mo STEEL	SCM435
404	PUMP FRAME	1	CAST IRON	FC200	CAST IRON	FC200
520	MECHANICAL SEAL	1	SiC & CARBON	-	SiC & CARBON	-
521	MECH. SEAL COVER	1	BRONZE	CAC402	BRONZE	CAC402
522	O-RING	1	RUBBER	NBR	RUBBER	NBR
523	RETAINING RING	1	STAINLESS STEEL	SUS304	STAINLESS STEEL	SUS304

Performance

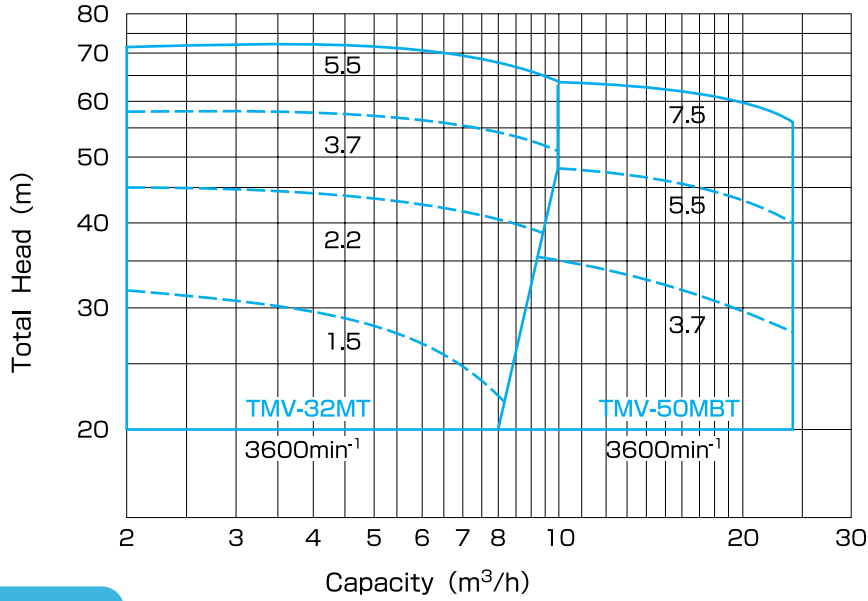

Dimension

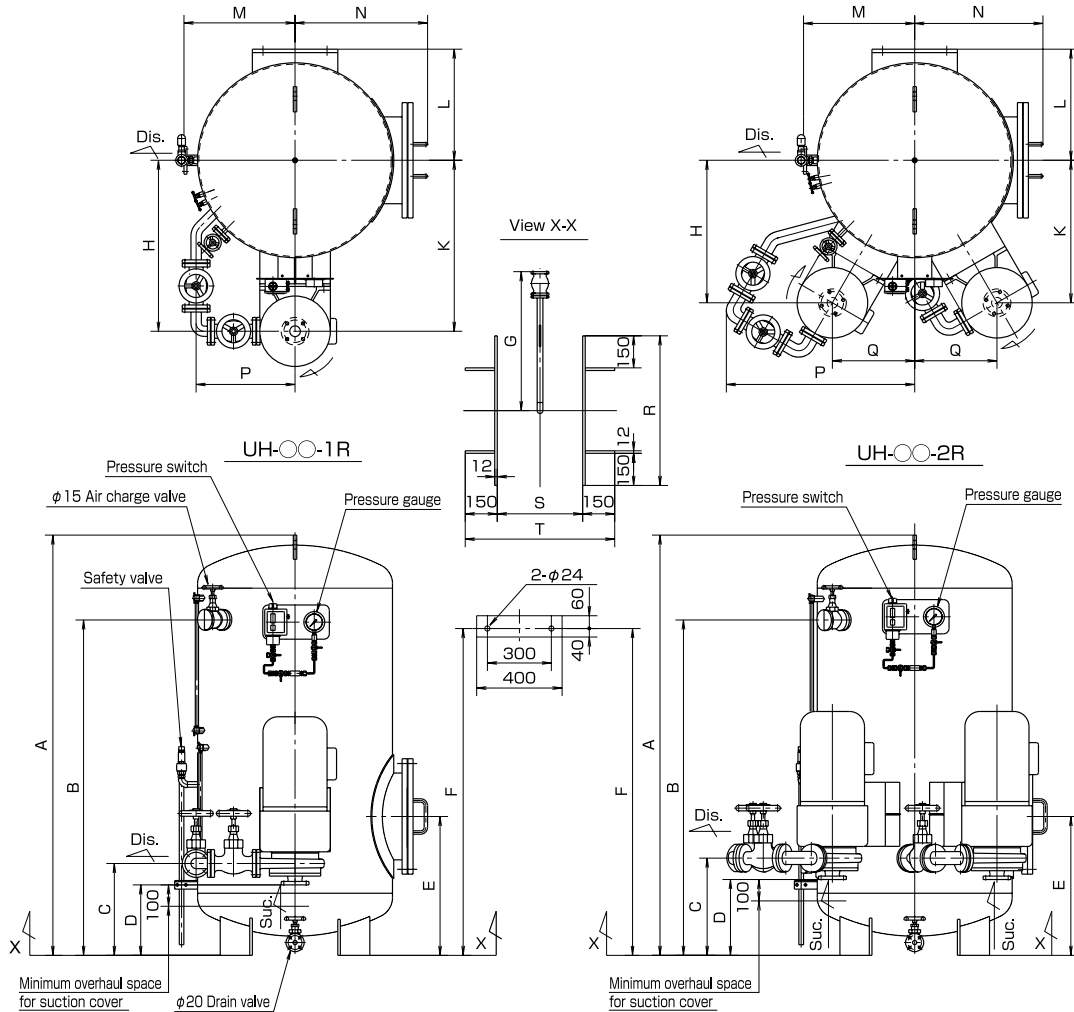

※mark is based on the bore size of attached pump.

Model No.	Bore		Tank Volume (L)	Dimension (mm)																
	Suc.	Dis.		A	B	C	D	E	F	G	H	K	L	M	N	P	Q	R	S	T
UH-0.5-1R	※	50	500	1198	805	450	350	600	795	625	680	680	495	520	595	260	—	700	400	700
UH-0.5-2R	※	50	500	1198	880	450	350	600	795	625	589	589	495	520	595	560	340	700	400	700
UH-1.0-1R	※	50	1000	1967	1570	450	350	650	1620	650	720	720	520	520	620	240	—	700	400	700
UH-1.0-2R	※	50	1000	1967	1570	450	350	650	1620	650	624	624	520	520	620	580	360	700	400	700
UH-1.5-1R	※	50	1500	1956	1530	450	350	700	1520	750	820	820	620	650	715	240	—	800	500	800
UH-1.5-2R	※	50	1500	1956	1530	450	350	700	1520	750	710	710	620	650	715	630	410	800	500	800
UH-2.0-1R	※	50	2000	2170	1700	450	350	750	1690	800	960	960	670	700	785	280	—	900	600	900
UH-2.0-2R	※	50	2000	2170	1700	450	350	750	1690	800	830	830	670	700	785	734	480	900	600	900