

TAIKO

GEAR PUMP
VG

GEAR



大晃機械工業株式会社
TAIKO KIKAI INDUSTRIES CO., LTD.

特長

Feature

VGシリーズは、
一般電動立形低圧・
内装軸受式歯車ポンプです。

VG series is motor driven
vertical low pressure internal
bearing type gear pumps.

- **歯形** : 世界にさきがけて考案された、
一点連続接触歯車”欠円ギヤー”
が標準です。



- **Tooth Profile** : To be the first in the world to design a
one-point-contact-gear called
“Segmental Gear” as our standard
model.

仕様

Specification

- **温度** : 取扱い油温は、最高80℃です。
- **軸受** : 内装軸受式で揚液による自己潤滑方式
のため、潤滑性を有する液に適します。
- **軸封** : グランドパッキン式が標準です。
ご要望に応じて、メカニカルシール式を
製作します。
- **フランジ** : 吸込、吐出し共JIS10Kです。
- **軸心** : ポンプと電動機との軸継手の芯の振れの
許容範囲は、回転速度2000~500min⁻¹
において、軸継手側面で0.1mm以下、
軸継手端面で0.1mm以下です。
- **水圧試験** : 計画仕様圧力の2倍が標準です。
最高1.20MPaです。
- **吐出し量** : 吐出し量は、吐出し圧力0.60MPa、粘度
25.8mm²/sにおける量です。
許容吸込圧力範囲は、ポンプ入口におい
て、-0.05~0.20MPaです。

- **Temperature** : Maximum handling oil temperature is
80℃.
- **Bearing** : Internal bearing is self-lubricated by
pumping liquid which is suitable to
serve lubricant fluids.
- **Shaft Seal** : The conventional gland packing is our
standard; however, the mechanical
seal type is also available.
- **Flange** : Both suction and discharge is JIS10K.
- **Cantering** : If connecting the pump with the motor,
the standard allowable alignment
value at the rate of 2000 to 500min⁻¹
at the shaft coupling side surface
should be under 0.1mm and at the
shaft coupling end surface should be
under 0.1mm.
- **Hydraulic Test** : Twice the value of the designed speci-
fication pressure with a maximum value
of 1.20MPa.
- **Capacity** : The following capacity shows at viscosity
of 25.8mm²/s with discharge
pressure of 0.60MPa.
The allowable suction pressure range
is -0.05 to 0.20MPa at the pump suction.

形番 Model No.	口径 Bore (mm) 吸込×吐出し Suc.×Dis.	吐出し量 Capacity (m ³ /h)			
		60Hz		50Hz	
		1200min ⁻¹	900min ⁻¹	1000min ⁻¹	750min ⁻¹
VG-15	100×80	15		12	
VG-20		20		16	
VG-25		25		20	
VG-30	125×100	30		25	
VG-35		35		29	
VG-40		40		33	
VG-50	150×125	50		40	
VG-65			65		55
VG-80			80		65
VG-90			90		75
VG-100			100		85

構造及び材質

Structure and Material

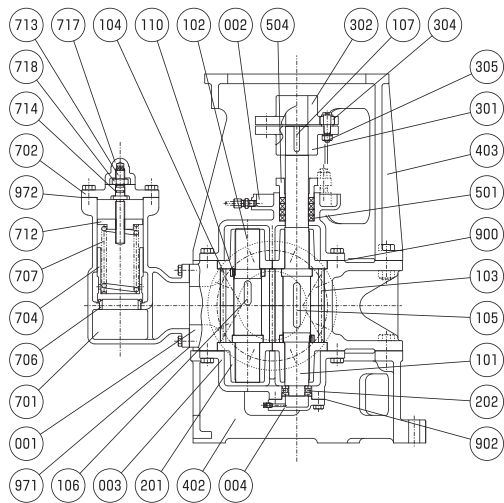

VG-15 to 50

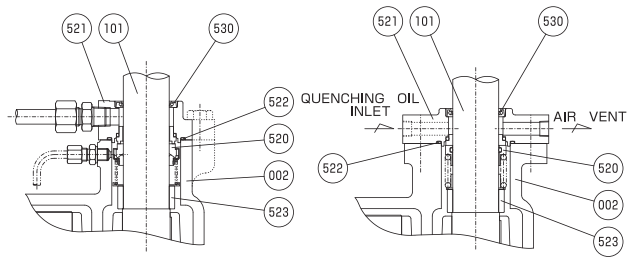

VG-00MT

VG-00MA

Detail for Mechanical Seal

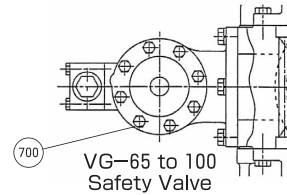

VG-65 to 100
Safety Valve

No.	Name		Material		Q'ty	No.	Name		Material		Q'ty
			Symbol	Name of Material					Symbol	Name of Material	
001	ケーシング	Casing	FC200	Cast iron	1	520	メカニカルシール	Mechanical seal	-	SiC & Carbon or Ceramic & Carbon	1
002	サイドカバー	Side cover	FC200	Cast iron	1	521	メカニカルシールカバー	Mech.seal cover	FC200	Cast iron	1
003	サイドカバー	Side cover	FC200	Cast iron	1	522	Oリング	O-ring	NBR	Rubber	1
004	エンドカバー	End cover	FC200	Cast iron	1	523	調整リング	Spacer	SS400	Mild steel	1
101	主動軸	Drive shaft	S45C	Carbon steel	1	530	オイルシール	Oil seal	NBR	Rubber	1
102	従動軸	Driven shaft	S45C	Carbon steel	1	700	逃し弁完備品	Safety v.complete	-	-	1
103	主動歯車	Drive gear	S45C	Carbon steel	1	701	逃し弁本体	Safety v.box	FC200	Cast iron	1
104	従動歯車	Driven gear	S45C	Carbon steel	1	702	逃し弁カバー	Safety v.cover	FC200	Cast iron	1
105	キー	Key	S45C	Carbon steel	1	704	逃し弁	Safety valve	S45C	Carbon steel	1
106	キー	Key	S45C	Carbon steel	1	706	弁座	Safety v.seat	SUS410	Stainless steel	1
107	キー	Key	S45C	Carbon steel	1	707	逃し弁ばね	Safety v.spring	SUP6	Spring steel	1
110	歯車締付ナット	Gear set ring	S45C	Carbon steel	2	712	ばね押さえ	Spring carrier	SS400	Mild steel	1
201	平軸受	Bearing metal	CAC603 or FC200+WJ1	Lead bronze or Cast iron+White metal	4	713	調整ねじ	Adjust screw	SS400	Mild steel	1
202	スラスト玉軸受	Thrust ball bearing	SUJ2	Bearing steel	1	714	Oリング	O-ring	NBR	Rubber	1
301	軸継手	Coupling	FC200	Cast iron	1	717	キャップ	Safety v.cap	FC200	Cast iron	1
302	軸継手	Coupling	FC200	Cast iron	1	718	ロックナット	Lock nut	SS400	Mild steel	1
304	軸継手用リング	Coupling ring	NBR	Rubber	8	900	ガスケット	Gasket	-	Paper	2
305	軸継手用ボルト	Coupling bolt	SS400	Mild steel	8	902	ガスケット	Gasket	-	Paper	1
402	ポンプ台	Pump bed	FC200	Cast iron	1	907	ガスケット	Gasket	-	Paper	1
403	フレーム	Frame	FC200	Cast iron	1	971	ガスケット	Gasket	-	Paper	1
501	グランドパッキン	Gland packing	-	Carbonized fiber	4	972	ガスケット	Gasket	-	Paper	1
504	グランド	Gland	CAC402	Bronze	1						

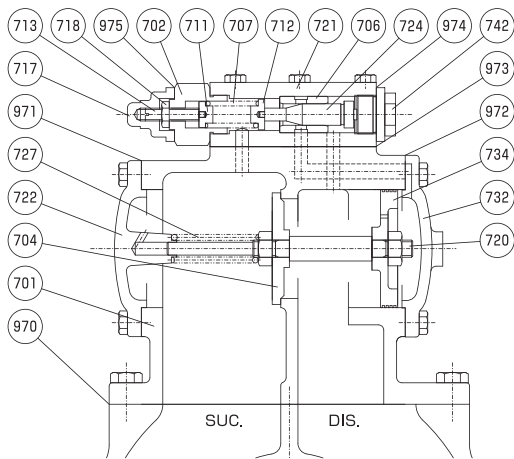

Parts No.700: Safety V.Complete
VG-65 to 100

NOTICE

This safety valve is not a pressure regulating valve. If required, please install a pressure regulating valve or bypass valve on the line.

No.	Name		Material		Q'ty
			Symbol	Name of Material	
701	逃し弁本体	Safety v.box	FC200	Cast iron	1
702	逃し弁カバー	Safety v.cover	SS400	Mild steel	1
704	逃し弁	Safety valve	S45C	Carbon steel	1
706	弁座	Safety v.seat	CAC402	Bronze	1
707	逃し弁ばね	Safety v.spring	SWPA	Piano wire	1
711	ばね押さえ	Spring carrier	SS400	Mild steel	1
712	ばね押さえ	Spring carrier	SS400	Mild steel	1
713	調整ねじ	Adjust screw	SS400	Mild steel	1
717	キャップ	Safety v.cap	FC200	Cast iron	1
718	ロックナット	Lock nut	SS400	Mild steel	1
720	ピストン棒	Piston rod	S45C	Carbon steel	1
721	逃し弁本体	Safety v.box	FC200	Cast iron	1
722	逃し弁カバー	Safety v.cover	FC200	Cast iron	1
724	逃し弁	Safety valve	SUS410	Stainless steel	1
727	逃し弁ばね	Safety v.spring	SWPA	Piano wire	1
732	逃し弁カバー	Safety v.cover	FC200	Cast iron	1
734	ピストン弁	Piston valve	S45C	Carbon steel	1
742	逃し弁カバー	Safety cover	FC200	Cast iron	1
970	ガスケット	Gasket	-	Paper	1
971	ガスケット	Gasket	-	Paper	1
972	ガスケット	Gasket	-	Paper	1
973	ガスケット	Gasket	-	Paper	1
974	ガスケット	Gasket	-	Paper	2
975	ガスケット	Gasket	-	Paper	1

寸法

Dimension

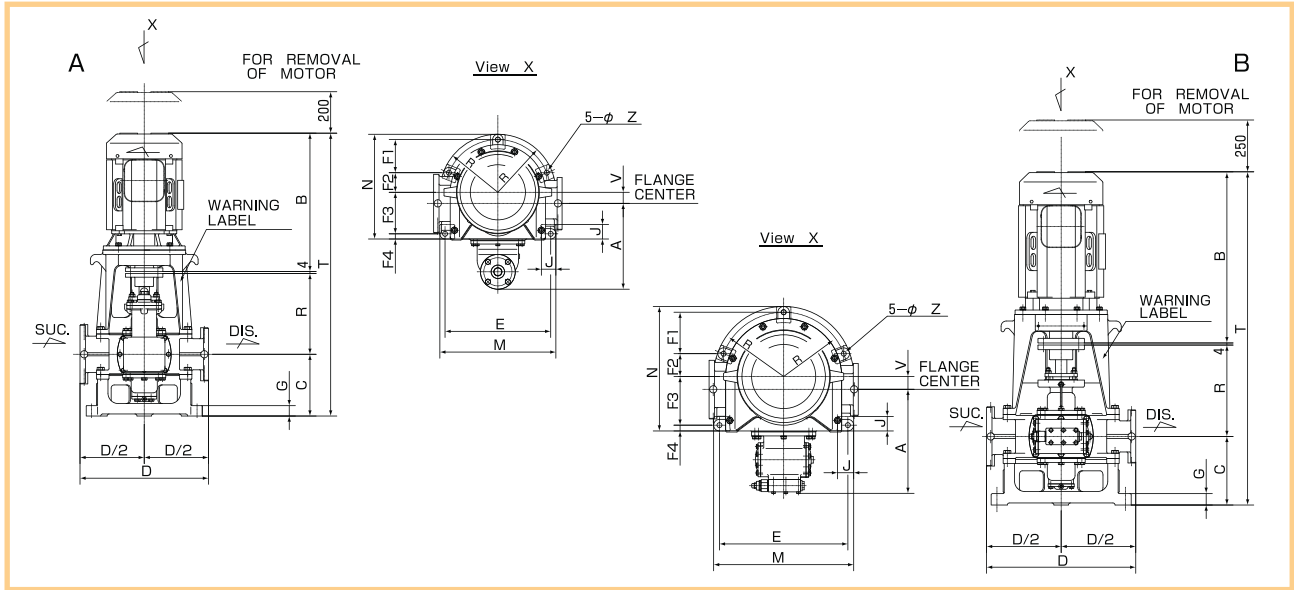

形番 Model No.	図 fig.	電動機 Motor		寸法 Dimensione (mm)																	質量 Weight (kg)		軸継手 Coupling		
		出力 Output (kW)	極数 Pole No.	A	B	C	D	E	F1	F2	F3	F4	G	J	K	M	N	O	R	T	V	Z		ポンプ Pump	電動機 Motor
VG-15	A	5.5	6	320	570	253	500	400	125	75	150	25	40	50	225	450	400	200	345	1172	45	23	220	86	A-160
		7.5			638															1240				115	
VG-30	A	7.5	6	320	638	265	500	400	125	75	150	25	40	50	225	450	400	200	345	1252	45	23	230	115	A-160
		11.0			678															1292				130	
VG-40	A	11.0	6	400	678	300	620	510	160	95	200	25	50	70	280	560	505	255	390	1372	53	23	340	130	A-180
		15.0			732															1426				180	
VG-50	A	15.0	6	400	732	290	620	510	160	95	200	25	50	70	280	560	505	255	390	1416	53	23	350	180	A-180
		18.5			770															1454				250	
VG-65	B	18.5	8	495	868	330	720	620	200	110	235	30	55	70	335	670	600	310	445	1647	62	24	500	340	A-200
		22.0			868															1667				340	
VG-80	B	22.0	8	495	868	350	720	620	200	110	235	30	55	70	335	670	600	310	445	1759	62	24	500	530	A-224
		30.0			960															1759				530	
VG-90	B	22.0	8	495	868	350	720	620	200	110	235	30	55	70	335	670	600	310	445	1667	62	24	500	340	A-224
		30.0			960															1759				530	
VG-100	B	30.0	8	525	960	417	780	680	215	125	250	30	60	80	370	740	650	340	515	1896	70	28	750	530	A-250

※電動機メーカー及び形番によりT,B寸法及び質量が異なります。
 Depend on motor manufacturer and model, measurement of T,B and weight maybe changed.

大晃機械工業株式会社 TAIKO KIKAI INDUSTRIES CO., LTD.

URL <http://www.taiko-kk.com>

- 本 社 ・ 工 場 〒742-1598 山口県熊毛郡田布施町大字下田布施209-1
 TEL: (0820) 52-3113~4 FAX: (0820) 53-1001 E-mail: business@taiko-kk.com
 - 東 京 支 店 〒101-0061 東京都千代田区三崎町3-4-9 水道橋MSビル4階
 TEL: (03) 3221-8551 FAX: (03) 3221-8555 E-mail: tokyo-br@taiko-kk.com
 - 大 阪 支 店 〒541-0048 大阪市中央区瓦町3-4-7 KCビル8階
 TEL: (06) 6231-6241 FAX: (06) 6222-3295 E-mail: osaka-br@taiko-kk.com
- 北京駐在事務所・上海駐在事務所・韓国大晃
- Head Office & Factory 209-1 Shimotabuse, Tabuse-cho, Kumage-gun, Yamaguchi pref. 742-1598 Japan
 TEL: 81-820-52-3113~4 FAX: 81-820-53-1001 E-mail: business@taiko-kk.com
 - Tokyo Branch 4th floor, Suidobashi MS Building, 3-4-9 Misaki-cho, Chiyoda-ku, Tokyo 101-0061 Japan
 TEL: 81-3-3221-8551 FAX: 81-3-3221-8555 E-mail: tokyo-br@taiko-kk.com
 - Osaka Branch 8th floor, KC Building, 3-4-7 Kawara-machi, Chuo-ku, Osaka 541-0048 Japan
 TEL: 81-6-6231-6241 FAX: 81-6-6222-3295 E-mail: osaka-br@taiko-kk.com
- Beijing Office・Shanghai Office・Taiko Korea

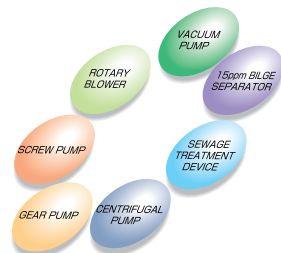

- ISO 9001の認証取得 お問い合わせ先の詳細は別紙【BUSINESS OFFICE NETWORK】をご覧ください。
- ISO 9001 certified For any inquiries, please refer to attached 【BUSINESS OFFICE NETWORK】
- このカタログに記載した製品は性能向上のため予告なしに寸法及び仕様を変更することがあります。
- The sizes and specifications of the products in this catalog are subject to improvement.