

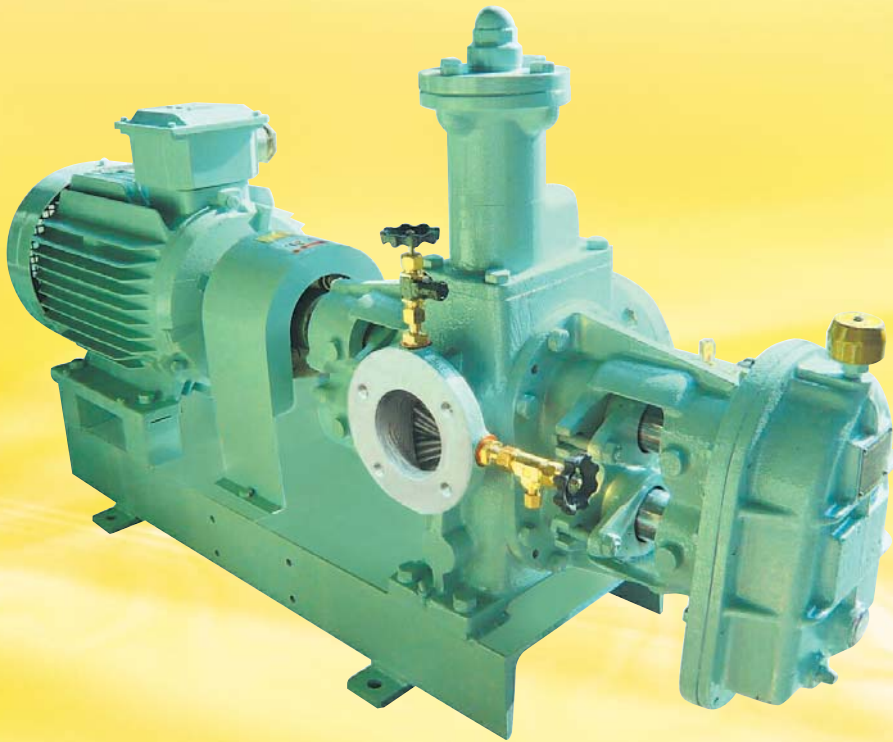

GEAR PUMP
WL

GEAR



大晃機械工業株式会社
TAIKO KIKAI INDUSTRIES CO., LTD.

特長

WLシリーズは、
一般電動横形低圧・
外装軸受式歯車ポンプです。

■ **歯形** : 世界にさきがけて考案された、
一点連続接触歯車"欠円ギヤ"が
標準です。

※WL-1~2: インボリュート歯車



Feature

WL series is motor driven
horizontal low pressure outernal
bearing type gear pumps.

■ **Tooth Profile** : To be the first in the world to design a
one-point-contact-gear called
"Segmental Gear" as our standard
model.

※WL-1 to 2 : Involute Gear

仕様

■ **温度** : 取扱い油温は、最高80℃です。

■ **軸受** : 外装軸受式で軸受は軸封により
揚液と隔離されているため、非潤滑
性液も扱えます。

■ **軸封** : グランドパッキン式が標準です。
ご要望に応じて、メカニカルシール式
を製作します。

■ **フランジ** : 吸込み、吐出し共JIS10Kです。

■ **軸心** : ポンプと電動機との軸継手の芯の振
れの許容範囲は、回転速度2000~
500min⁻¹において、軸継手側面で
0.1mm以下、軸継手端面で0.1mm
以下です。

■ **水圧試験** : 計画仕様圧力の2倍が標準です。
最高1.20MPaです。

■ **吐出し量** : 吐出し量は、吐出圧力0.60MPa、
粘度25.8mm²/sにおける量です。
許容吸込圧力範囲は、ポンプ入口に
おいて、-0.05~0.20MPaです。

Specification

■ **Temperature** : Maximum handling oil temperature is 80℃.

■ **Bearing** : This pump is outernal bearig type that
isolates bearings from pumping
liquid by shaft seals so that it can handle
none lubricating liquids.

■ **Shaft Seal** : The conventional gland packing is our
standard; however, the mechanical
seal type is also available.

■ **Flange** : Both suction and discharge are JIS10K.

■ **Centering** : If connecting the pump with the motor,
the standard allowable alignment value
at the rate of 2000 to 500min⁻¹at the
shaft coupling side surface should be
under 0.1mm and at the shaft coupling
end surface should be under 0.1mm

■ **Hydraulic Test**: Twice the value of the designed
specification pressure with a maximum
value of 1.20MPa.

■ **Capacity** : The following capacity shows at
viscosity of 25.8mm²/s with discharge
pressure of 0.60MPa.
The allowable suction pressure range
is -0.05 to 0.20MPa at the pump
suction.

形番 Model No.	口径 Bore (mm) 吸込み×吐出し Suc.×Dis.	吐出し量 Capacity (m ³ /h)			
		60Hz		50Hz	
		1200min ⁻¹	900min ⁻¹	1000min ⁻¹	750min ⁻¹
WL-1	20×20	1		0.8	
WL-2		2		1.6	
WL-3	25×25	3		2.5	
WL-4		4		3.3	
WL-5	32×32	5		4	
WL-6		6		5	
WL-7.5	40×40	7.5		6	
WL-10		10		8	
WL-12	50×50	12		10	
WL-15		15		12	
WL-20	65×65	20		16	
WL-25		25		20	
WL-30	80×80	30		25	
WL-40		40		33	
WL-50	100×100	50		40	
WL-65			65		55
WL-80	150×150		80		65
WL-100			100		85

構造及び材質

Structure and Material

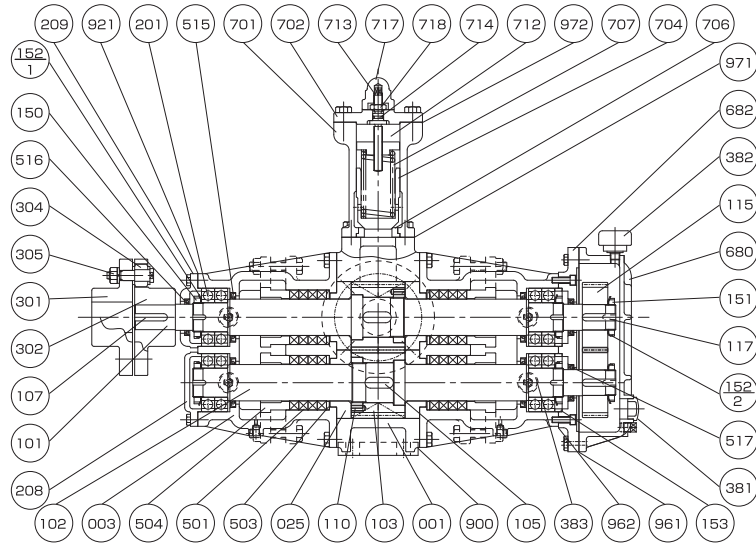

WL-1~25

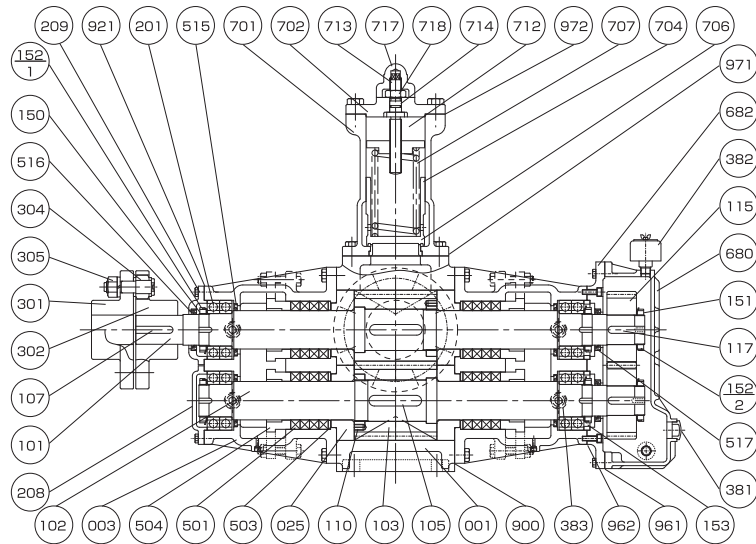

WL-30~100

No.	Name	Material			No.	Name	Material		
		Symbol	Name of Material	Q'ty			Symbol	Name of Material	Q'ty
001	ケーシング Casing	FC200	Cast iron	1	383	グリースカップ Grease cup	SG295	ST.for GAS.CYL	4
003	サイドケース Side case	FC200	Cast iron	2	501	グランドパッキン Gland packing	—	Carbonized fiber	16
025	サイドプレート Side plate	FCD400	Ductile cast iron	4	503	パッキン座 Packing seat	S45C	Carbon steel	4
101	主動軸 Drive shaft	S45C	Carbon steel	1	504	グランド Gland	FC200	Cast iron	4
102	従動軸 Driven shaft	S45C	Carbon steel	1	515	オイルシール Oil seal	NBR	Rubber	4
103	ポンプ歯車 Gear	S45C	Carbon steel	2	516	オイルシール Oil seal	NBR	Rubber	1
105	キー Key	S45C	Carbon steel	2	517	オイルシール Oil seal	NBR	Rubber	2
107	キー Key	S45C	Carbon steel	1	680	ギヤボックス Gear box	FC200	Cast iron	1
110	歯車締付ナット Gear set ring	S45C	Carbon steel	2	682	ギヤボックス取付板 Box plate	FC200	Cast iron	1
115	駆動歯車 Pilot gear	S45C	Carbon steel	2	701	逃し弁本体 Safety v. box	FC200	Cast iron	1
117	キー Key	S45C	Carbon steel	2	702	逃し弁カバー Safety v. cover	FC200	Cast iron	1
150	軸受用ナット Bearing nut	SS400	Mild steel	4	704	逃し弁 Safety valve	S45C	Carbon steel	1
151	軸受用ナット Bearing nut	SS400	Mild steel	2	706	弁座 Safety v. seat	SUS410	Stainless steel	1
152/1	軸受用座金 Bearing washer	SS400	Mild steel	4	707	逃し弁ばね Safety v. spring	SUP6	spring steel	1
152/2	軸受用座金 Bearing washer	SS400	Mild steel	2	712	ばね押さえ Spring carrier	S45C	Mild steel	1
153	カラー Collar	S45C	Carbon steel	2	713	調整ねじ Adjust screw	SS400	Mild steel	1
201	玉軸受 Bearing	SUJ2	Bearing steel	8	714	Oリング O-Ring	NBR	Rubber	1
208	軸受カバー Bearing cover	FC200	Cast iron	1	717	キャップ Safety v. cap	FC200	Cast iron	1
209	軸受カバー Bearing cover	FC200	Cast iron	1	718	ロックナット Lock nut	SS400	Mild steel	1
301	軸継手 Coupling	FC200	Cast iron	1	900	ガスケット Gasket	—	Paper	2
302	軸継手 Coupling	FC200	Cast iron	1	921	ガスケット Gasket	—	Paper	2
304	軸継手用リング Coupling ring	NBR	Rubber	8	961	ガスケット Gasket	—	Paper	1
305	軸継手用ボルト、ナット Coupling bolt & nut	SS400	Mild steel	8	962	ガスケット Gasket	—	Paper	1
381	レベルゲージ Level gauge	ACRYL	Acryl plate	1	971	ガスケット Gasket	—	Paper	1
382	エアブリーザー Air brether	SS400	Mild steel	1	972	ガスケット Gasket	—	Paper	1

寸法

Dimension

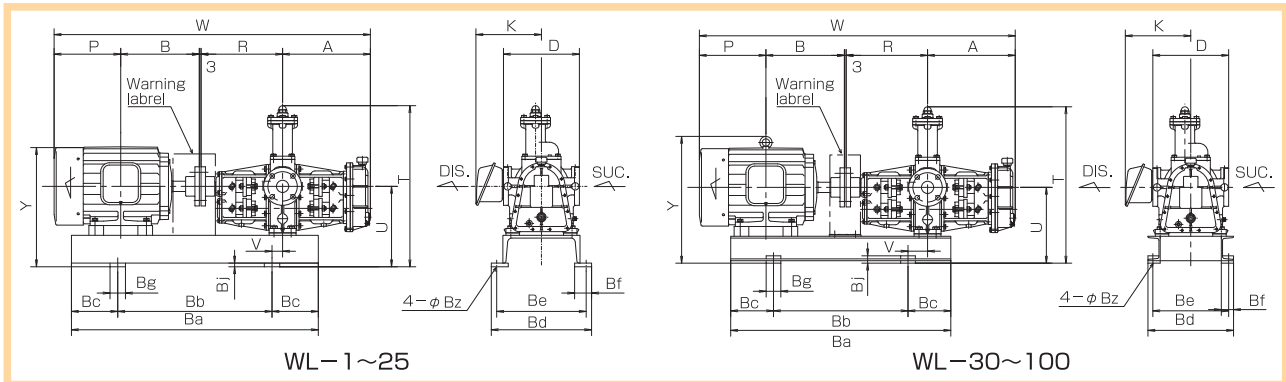

形番 Model No.	電動機 Motor		寸法 Dimension (mm)																	質量 Weight (kg)			軸継手 Coupling															
	出力 Output (kW)	極数 Pole No.	A	B	D	K	P	R	T	U	V	W	Y	Ba	Bb	Bc	Bd	Be	Bf	Bg	Bj	Bz		ポンプ Pump	台板 Base	電動機 Motor												
WL-1 2	0.75	6	270	168.5	240	160	143	245	455	260	45	829.5	356	600	400	100	325	290	55	50	12	15	45	25	19	A-125												
	1.5	6		193		165	169					880	398														600	400	100	325	290	55	50	12	15	45	25	31
	2.2	6		200		175	176					894	417																									
WL-3 4	1.5	6	295	193	240	165	169	265	480	270	45	925	408	600	400	100	325	290	55	50	12	15	55	26	31	A-125												
	2.2	6		200		175	176					939	427														700	450	125	325	290	55	50	12	15	55	29	41
	3.7	6		236		190	208					1010	443																									
WL-5	2.2	6	300	200	260	175	176	275	510	270	50	954	427	700	450	125	325	290	55	50	12	15	60	29	41	A-140												
	3.7	6		239		190	208					1025	443														700	450	125	325	290	55	50	12	15	60	29	41
	5.5	6		258		190	227					1115	463																									
WL-6 7.5	2.2	6	345	200	280	175	176	320	610	290	60	1044	447	700	450	125	325	290	55	50	12	15	70	30	41	A-140												
	3.7	6		239		190	208					1115	463														800	500	150	325	290	55	50	12	15	70	33	58
	5.5	6		258		190	227					1153	473																									
WL-10	3.7	6	360	239	310	190	208	335	630	300	60	1145	473	800	500	150	390	350	65	50	12	15	85	30	58	A-160												
	5.5	6		258		190	227					1183	513														900	550	175	390	350	65	50	12	15	85	42	105
	7.5	6		323		265	252					1273	513																									
WL-12 15	11	6	390	345	320	265	274	360	695	315	70	1238	488	900	550	175	390	350	65	60	12	19	100	46	105	A-160												
	5.5	6		323		265	252					1328	528														1000	600	200	470	390	60	12	19	100	51	130	
	7.5	6		345		290	295					1372	572																									1000
WL-20 25	15	6	390	351.5	320	290	295	360	705	325	100	1339.5	572	1000	600	200	470	390	60	60	12	19	100	51	175	A-180												
	11	6		345		265	274					1392	553														1100	400	150	450	410	50	60	30	19	140	68	130
	15	6		351.5		290	314					1419.5	587																									
WL-30	11	6	400	345	350	265	274	370	730	340	40	1542	573	1100	400	150	450	410	50	60	30	19	140	68	175	A-180												
	15	6		351.5		290	314					1457.5	587														1100	400	150	450	410	50	60	30	19	140	68	175
	18.5	6		370.5		290	314					1457.5	587																									
WL-40 50	11	6	480	345	400	265	274	400	810	360	20	1542	573	1100	400	150	450	410	50	60	30	19	210	80	130	A-200												
	15	6		351.5		290	314					1569.5	607														1200	450	150	450	410	50	60	30	19	210	86	220
	18.5	6		370.5		290	314					1607.5	607																									
WL-65	22	6	520	425.5	430	350	371	500	980	420	10	1719.5	685	1300	500	150	500	450	65	80	30	24	300	118	335	A-224												
	15	8		370.5		290	314					1707.5	667														1300	500	150	500	450	65	80	30	24	300	118	335
	18.5	8		432		375	380					1835	797																									
WL-80 100	30	8	520	425.5	470	350	371	520	1010	430	5	1839.5	780	1400	550	150	550	500	65	80	30	24	380	138	335	A-250												
	18.5	8		432		375	380					1855	807														1400	550	150	550	500	65	80	30	24	380	148	480
	22	8		463.5		443	415					1921.5	873																									
37	8	482.5	443	434	1959.5	873	1400	550	150	550	500	65	80	30	24	380	148	480																				
45	8	482.5	443	434	1959.5	873													1400	550	150	550	500	65	80	30	24	380	148	480								

※電動機メーカー及び形番によりW, P, Y, K寸法及び質量が異なります。
 Depend on motor manufacturer and model, measurement of W, P, Y, K and weight maybe changed.

大晃機械工業株式会社 TAIKO KIKAI INDUSTRIES CO., LTD.

URL <http://www.taiko-kk.com>

- 本 社 ・ 工 場 〒742-1598 山口県熊毛郡田布施町大字下田布施209-1
 TEL: (0820) 52-3113~4 FAX: (0820) 53-1001 E-mail: business@taiko-kk.com
 - 東 京 支 店 〒101-0061 東京都千代田区三崎町3-4-9 水道橋MSビル4階
 TEL: (03) 3221-8551 FAX: (03) 3221-8555 E-mail: tokyo-br@taiko-kk.com
 - 大 阪 支 店 〒541-0048 大阪市中央区瓦町3-4-7 KCビル8階
 TEL: (06) 6231-6241 FAX: (06) 6222-3295 E-mail: osaka-br@taiko-kk.com
- 北京駐在事務所・上海駐在事務所・韓国大晃

- Head Office & Factory 209-1 Shimotabuse, Tabuse-cho, Kumage-gun, Yamaguchi pref. 742-1598 Japan
 TEL: 81-820-52-3113~4 FAX: 81-820-53-1001 E-mail: business@taiko-kk.com
 - Tokyo Branch 4th floor, Suidobashi MS Building, 3-4-9 Misaki-cho, Chiyoda-ku, Tokyo 101-0061 Japan
 TEL: 81-3-3221-8551 FAX: 81-3-3221-8555 E-mail: tokyo-br@taiko-kk.com
 - Osaka Branch 8th floor, KC Building, 3-4-7 Kawara-machi, Chuo-ku, Osaka 541-0048 Japan
 TEL: 81-6-6231-6241 FAX: 81-6-6222-3295 E-mail: osaka-br@taiko-kk.com
- Beijing Office・Shanghai Office・Taiko Korea

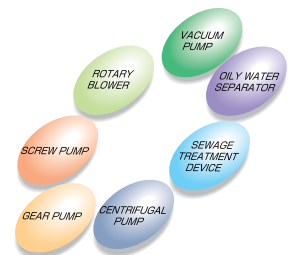

- ISO 9001の認証取得 お問い合わせ先の詳細は別紙【BUSINESS OFFICE NETWORK】をご覧ください。
- ISO 9001 certified For any inquiries, please refer to attached 【BUSINESS OFFICE NETWORK】
- このカタログに記載した製品は性能向上のため予告なしに寸法及び仕様を変更することがあります。
- The sizes and specifications of the products in this catalog are subject to improvement.